

Accessory

HY-8-102

Capacity	Part number
0.5t-2t	HY-8-102-0.5/2t
2.5t-5t	HY-8-102-2.5/5t
1K-4KSE	BY-8-104-1/4KSE
5K-10K	BY-8-104-5/10K

Features:

Easy installation, automatically centralized with steel ball, good self-aligning ability.
Mainly used for platform scales and other electronic weighing devices.



Outline Dimension mm(inch)

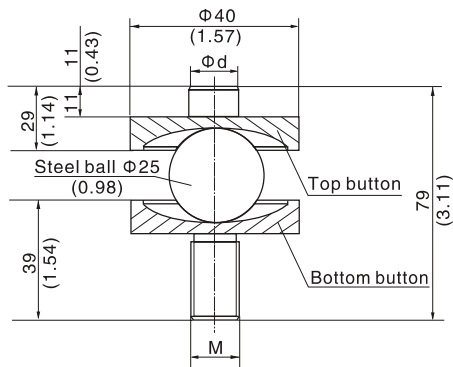

Dimension Capacity	Φd	M
0.5t-2t 1K-4KSE	12 (0.47)	M12 \times 1.75
2.5t-5t 5K-10K	18 (0.71)	M18 \times 1.5